

HDR For Cinematography

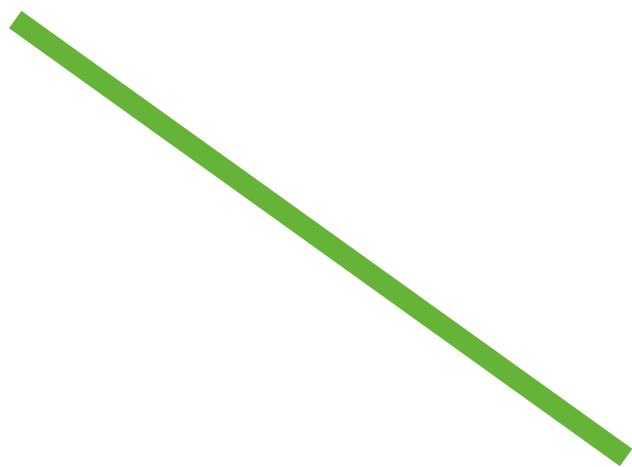

Essential Guide

EG

ESSENTIAL GUIDES

Introduction

High dynamic range and wide color gamut combined with 4K resolution and progressive frame rates have catapulted broadcast television to new levels of immersive experience for the viewer. As HDR and WCG are relatively new to television, we need to both understand their application and how we monitor them to enable us to surpass the levels of quality and immersive experience cinematographers demand.

Although engineers have worked with creatives and program makers throughout the history of television, HDR and WCG brings a new level of creativity that needs to be understood. The “artistic intent” isn’t just a number we can measure to or calibrate for. Instead, to understand this completely, we must have a much greater awareness of the creative and artistic process.

In television circles, camera log curves seem to be spoken about with almost an air of mystery. They may be used extensively in cinematography but are seemingly new concepts for broadcasters. The irony is that we’ve been using gamma curves for as long as we’ve had television, and these are just a variation on a theme of camera log curves.

PQ and HLG further adds to our interest as they seem to be very similar but are also worlds apart. HLG solves many of the challenges for live television and many argue PQ provides greater creative freedom, and this is even more apparent when we look at future proofing our archives.

HDR has abstracted away the concept of peak brightness in terms of peak white being a particular voltage level. NITs are playing an increasingly important role for measuring brightness and how this compares to voltage levels is often challenging, especially when making programs for PQ and HLG.

As well as providing the new vibrant Rec.2020 color space, WCG has exposed some of the inefficiencies of our traditional YCbCr color difference signal representations. The distortions caused in 4:2:2 and 4:2:0 color subsampling may not have necessarily been apparent in standard dynamic range, but the associated higher quality of Rec.2020 lays these artefacts wide open, becoming even more apparent in post-production.

New color difference systems such as the ICtCp representation provide some solutions to these distortions due to constant illuminance representation. This makes distribution through traditional workflows a challenge and is reason for further consideration as we build cinematography compliant workflows.

HDR is much more than just a marginal increase in picture quality. It opens up a whole new level of creativity that we must work with and embrace.

Tony Orme
Editor, The Broadcast Bridge



Tony Orme.

HDR For Cinematography



By Tony Orme, Editor at The Broadcast Bridge

Broadcast television is entering a new and unprecedented chapter due to the need to provide high end cinematography productions. Although high quality productions have been in existence for as long as television has existed, their quality has been constrained by the limits and compromises live television imposes. In this Essential Guide, we look at how HDR has influenced our ability to produce cinematography productions.

Television is still constrained by the decisions made in the 1930's for black and white and 1960's for color transmission. Frame rates, resolutions and color spaces are all affected. The predominant influencing factor was the cathode ray tube as this was the major source of limitation. The resolution of the CRT was not only limited by the granularity of the phosphors, but also the light spill to neighboring phosphors causing a gaussian response resulting in reduced contrast as well as resolution.

The advent of CMOS and CCD image gathering devices, along with flat screen television, has greatly improved the viewer experience. A typical dynamic range for a CRT is in the order of 100:1, but modern cameras, with their improved sensors, now have a dynamic ratio of up to 10,000:1. To correctly resolve this range and avoid contouring, 14 bits of resolution is required. These sensor improvements also make wide color gamut available giving a greater and extended color range, especially in the greens.

Non-Linear Response

The human eye's sensitivity to contrast is non-linear in nature. That is, the greater the brightness, the greater the contrast ratio between objects must be for the eye to detect any differences. This relationship is known as Weber's law.

We use Weber's law to help determine the bit depth of the data needed to represent the sample. In digital video, our ability to detect the difference in brightness levels between adjacent quantization levels indicates the effects of contouring. Our ability to detect the difference between brightness levels is proportional to the brightness of the area being considered. This leads to the "just noticeable difference" between light-levels being a fraction of the light level. Also known as the Weber fraction, it determines the response of the cones in the eyes, that is, our color receptors. The eye can detect a change of 2% to 3% in brightness levels.

The 2% Weber fraction leads onto the 8-bit digital coding system used in broadcast television for Rec 709 systems, that is those based on the CRT technology. For cameras with a dynamic range of 10,000:1, then 14 bits are needed giving 16,384 quantizing levels.

10-bit Infrastructures

Even though broadcast infrastructures tend to use 10-bit SDI, the challenge we have is how do we make a 14-bit camera video feed work in a 10-bit SDI system? Especially when we consider that broadcast delivery systems to the home are 8-bits. If we just truncate the 14-bit data down to 10-bits, then we will have high visibility banding.

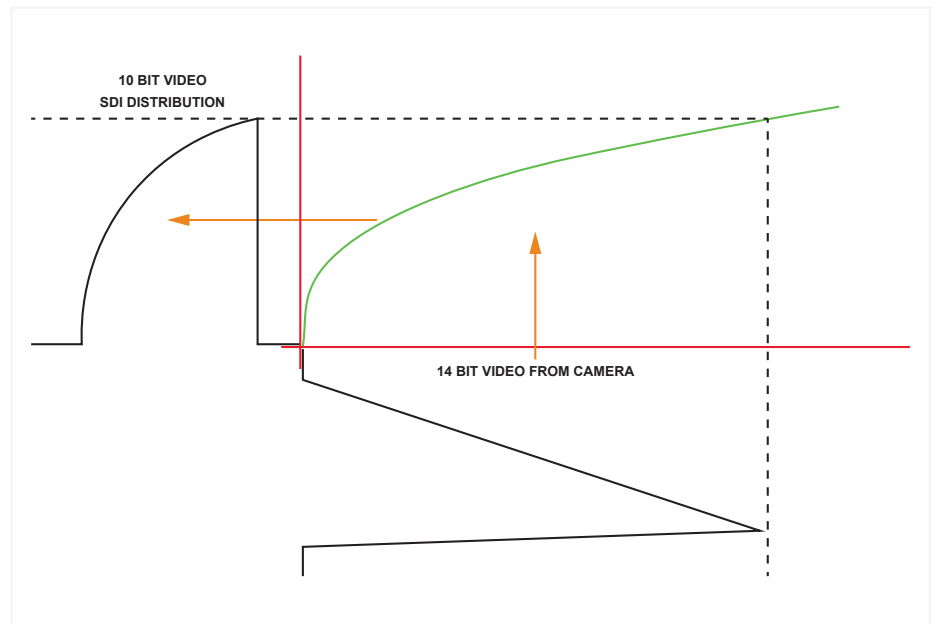

The primary purpose of S-Log, HLG and PQ is to fit the 14-bit video into a much smaller data space, in the case of SDI this is 10-bits. This diagram shows how S-Log takes a 14-bit video signal and converts it to 10-bits using the logarithmic transform. It has the added benefit of expanding the shadows and sympathetically compressing the highlights so more of the original image can be recovered during grading and editing.

In the analog days, broadcast television used the gamma curve to produce a uniform perception of video noise. The noise was generally introduced in the transmission chain which resulted in the CRT display compressing it when the opposite function was applied during display. This inversed gamma function was a natural attribute of the CRT's current to light response.

One of the properties of the human visual system is that we can perceive noise more in the shadows than we can in the highlights. This also means that we have a greater ability to detect contouring in the shadows. Gamma helps provide greater resolution in the dark areas of the screen to reduce contouring as well as giving better signal to noise.

Knee Dynamic Range

Even in SDR, vendors have been able to provide a dynamic range greater than that of the processing and display system. The "knee" is a method vendors use to increase the dynamic range limitations of the 8- or 10-bit broadcast infrastructure and delivery systems. The knee provides a compression function in the highlights to remove the effects of the hard clip and reduce the ballooning of specular highlights.

The primary reason for providing the knee was to extend the effective dynamic range while at the same time maintaining compatibility with existing working formats. The only problem with the knee is that each vendor has their own take on what it should do and how it should work. Consequently, there is no standardization and it's very difficult to work with in post-production.

Broadcast television fundamentally differs from cinematography as it is live, and the emphasis is on making programs work now, as opposed to recording them and editing in post later on. This allows cinematographers to spend much more time on making programs and editing them later, time live broadcasters cannot afford.

One consequence of this philosophy is that cinematographers record images to a much higher rate than we would generally have in broadcast television. 4KP60 4:4:4 images can be recorded and the new SMPTE 2082 standards even provide the option for 12-bit distribution. But even at this high resolution, there is still a need to provide a method of compression so that the images can be mapped from 14-bit resolution.

Greater Flexibility

Companies such as Netflix are placing great demands on cinematographers for the productions they supply. Dolby Vision is the norm at 4KP60 with full resolution 4:4:4 color subsampling at 12-bits.

Even with these formats, the resolution of the cameras still exceeds that of the playout and broadcast system. Furthermore, cameras are going to improve at a greater rate than our ability to change the broadcast formats thus demanding greater flexibility in the system.

Camera manufacturers have provided their own solutions to acquisition by using versions of logarithmic transfer functions to map the 14-bit video from the camera sensor to something more manageable such as 10- or 12-bit 4:4:4. Transfer functions such as S-Log from Sony, LogC from Arri, Canon-Log, and Blackmagic Log, all contribute to helping squeeze as much information into the 10- or 12-bit distribution and recording system as possible to maintain compatibility with existing infrastructures.

It's also worth remembering that the formats HLG and PQ are completely different than one of the log format's leaving the camera. For example, a live broadcaster might use Hybrid Log Gamma for their production, so they would only use the HLG output. If recording a movie production, then one of the camera log formats might be used and then processed in post.

Recording Log Formats

Even though PQ is used as a delivery and transmission format for the broadcaster, the cinematographer will still need to record in a log format for later post processing.

This also adds another interesting challenge, the cinematographer had much greater dynamic range and latitude when they were shooting using one of the 14-bit cameras for SDR productions. The camera-log recordings allowed the color-grader to effectively lift detail from the shadows and highlights when color correcting as there is much more information in the HDR image than can be seen by the naked eye allowing easier conversion to SDR. As the cinematographer is now thinking in HDR terms, the latitude for error has been much reduced so they must focus more on making sure the images are correct during acquisition.

There was a time when the cinematographer would have known they could have fixed a problem in post as there was a much higher margin for error when shooting for SDR. However, as we move to HDR productions, this margin of error has almost been completely removed. There is still some latitude as the image is providing 14-bit data and a company such as Netflix requires 12-bits, but there's not much in it.

Viewing Conditions

HLG and PQ are the two distribution formats that are playing out in the HDR arena. Although both have their good points, HLG is proving the most applicable to live productions. The system is scene referred so the broadcasters cannot make any assumptions about the viewers home television or mobile device.

Consequently, the signal-to-light relationship must be maintained. HLG is often graded and shaded for 1000cd/m² but a limit is none the less imposed.

It's worth remembering that the potential brightness of a home television, often expressed in NITs, is not intended to be the brightness of the whole screen. If we were to sit close to a 1,500-NIT television with a peak white signal displayed, then the viewer would certainly find the experience uncomfortable. Instead, the maximum brightness level of a television or monitor refers to the brightness of specular highlights and peak transients.

This leads onto some interesting situations for cinematographers. HLG works well for live events as it is scene referred and there is still a direct relationship between the light level of the scene and the HDR signal level. PQ is display referred and allows the cinematographer to make some fundamental assumptions about the viewing environment.

Although PQ can work in the live environment, it certainly excels in the making of high-end movies. Metadata established during the grading and editing process provides information about how the image should be displayed. The viewers television or mobile device then uses this information to calibrate the screen so that it displays the cinematographer's images as intended, often referred to as "artistic intent".

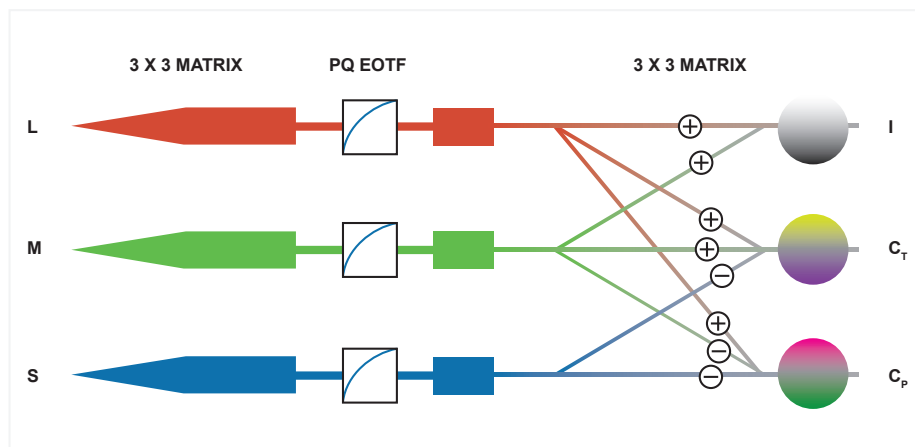

The IC₁C_p color method is still a color difference system similar to YC_bC_r, however, it takes advantage of some of the adaptive aspects of the human visual system to provide color subsampling that exhibits fewer artifacts when processing in post-production.

Color Subsampling Opportunities

PQ even facilitates a different method of providing color subsampling that helps maintain the image quality during post-production. Although IC_tC_p can be used with HLG, the need to make HLG compatible with existing live infrastructures, greatly restricts its use. Cinematography doesn't suffer this restriction. After the days shoot, the rushes are taken to the post house for grading and later editing, generally using software-based systems that are not real-time critical.

IC_tC_p is similar to YC_rC_b in that it is a color difference system. "I" is the intensity luma component, Ct is blue-yellow tritanopia color component, and Cp is the red-green protanopia color component. It differs from YC_rC_b as it improves color subsampling and hue linearity. The key with IC_tC_p is that it provides color uniformity by taking advantage of some of the aspects of the human visual system by optimizing lines of constant hue, uniformity of just-noticeable-difference, and constant illuminance. YC_bC_r introduces distortions into saturated colors when subsampled due to the nonconstant attributes of the luminance. This does not occur in IC_tC_p due to the nearly constant illuminance representation.

Mimicking the human eye, IC_tC_p has three distinct operations; the incoming light is captured by three types of cones that have peak sensitivity for the long (L), medium (M), and short (S) wavelengths. This captured linear light is converted into a non-linear signal to simulate the adaptive cone response of the HVS. And these non-linear signals are processed by a color differencing system in three different pathways to simulate the light-dark (intensity), yellow-blue (tritan isoluminant), and the red-green (protan isoluminant).

The major benefit for using IC_tC_p is found in post-production where multiple image processing is performed. Methods of converting RGB from YC_bC_r demonstrate significant artifacts and these are greatly reduced with the IC_tC_p conversions. As cameras and monitors improve, any of the non-linearity's seen in YC_bC_r are quickly seen, but processing IC_tC_p mitigates this.

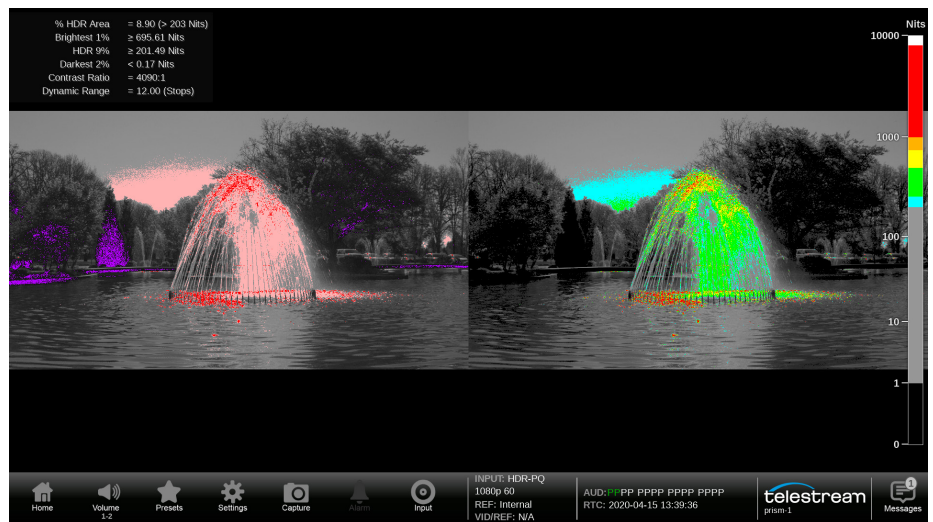

Tektronix display showing false color mode to show out of gamut colors.

No Longer Shackled to YCbCr

The IC_tC_p method can be used quite happily by the cinematographer if they decide to do so. They are not shackled by the same time constraints as the broadcasters.

Cinematographers also need new methods of monitoring. For the first time in nearly fifty years, we have made a significant change to the color space. Rec.2020 has a much greater vibrancy than Rec.709, especially in the greens and reds. Consequently, anybody working in television must now think more carefully about color space, especially with out of gamut errors.

On screen displays showing potential errors with color gamut are ideal and are much more descriptive and easier to use, especially in the field. The false color mode is a method of highlighting areas of the picture where the colors exceed the color gamut.

Linear Displays

The key luminance percentages used in HDR are 90% reflectance and 18% grey. Displays that can reverse the OETF of the camera, that is the log transfer function used, allow the cinematographer to continuously view the linear image from the camera without having to be concerned with the transfer function characteristics of the camera.

Look up tables (LUTs) are a convenient method of transferring from the log image to linear display and further facilitate how the data is presented to the cinematographer. Consequently, the luminance can be displayed in either NITS or f-stops.

The advent of HDR and WCG is not only providing broadcasters with new and improved images to help enhance the viewers immersive experience, it is also providing new opportunities for cinematographers looking to deliver higher quality images than would have been traditionally possible in live television.

Cinematographers are able to use new features within HDR and WCG that are not applicable to broadcasters as there is no great need to maintain compatibility with such systems. This has opened up a whole new plethora of opportunities for cinematographers.

The Sponsors Perspective

How HDR Has Blurred Lines Between TV And Cinema

By Ian Valentine, VP of Product Management, Telestream

Twenty years ago, there was a clear divide between how you shot and finished a project for Cinema compared to the typical workflows used in broadcast TV. With the advent of streaming services that provide 4K/UHD to a broad audience the lines are now blurred between these two worlds.



Further, the technology to provide high resolution and high dynamic range cameras and displays is today considered mainstream and accessible by even modest production budgets. The challenge now is how to up-level the skills and tools of a much larger population of production teams to support this transition.

As a longtime provider of tools for broadcast television, Telestream (as Tektronix) pioneered all the measurement displays that are familiar to broadcasters but were geared to a world that was constrained by 1960s television –over the air signals received by CRTs.

Supported by

Brightness levels were limited to the technology of the CRT and the color had to be constrained to fit into the available broadcast spectrum. Consequently, the production jobs were about making sure you balanced your blacks, kept your whites from clipping and then didn't violate the government regulations for color gamut. The new standards for UHD that provide higher resolution, a larger dynamic range, and a wider gamut of colors have pushed past these boundaries to create amazing pictures, but they've also pushed past the usefulness of tools that were used fifty years ago. As a result, Telestream has worked on a next generation toolset that can be used to get the most out of what UHD can provide.

Traditional Vs New HDR/WCG Tools

Broadcast production teams are familiar with traditional waveform and picture analysis, even though HDR workflows will require additional new analysis tools, enhancements to traditional tools also helps production teams' transition. PRISM has enhanced the traditional tools to support HDR/WCG including waveform and picture analysis with upgraded graticules and cursors to support multiple gamma types (SMPTE PQ 2084, HLG, plus camera gammas like Slog2 and Slog3). Readouts for the graticules and cursors are available in nits and stops, in addition to the traditional IRE percentage and millivolts. PRISM adds the ability to view an HDR trace display and picture converted to SDR for a quick SDR workflow check. This enables an engineer or operator to view HDR and SDR traces and pictures side by side on a four-tile display, to ensure video will display well on both television types.

PRISM then adds new HDR/WCG monitor and analysis tools. The stop-waveform is a new way to display the luminance levels in terms of linear display light or linear light. Changes in luminance level are represented in the stop-waveform in a linear manner; for linear display of PQ and HLG workflows in nits; and linear scene for Slog2/3 camera gamma in stops. There's no need to convert from mV or IRE, light levels are displayed to easily determine the dynamic range or stop difference between two points on an image. It's very powerful when used with the Light Meter to cross check and set light levels.

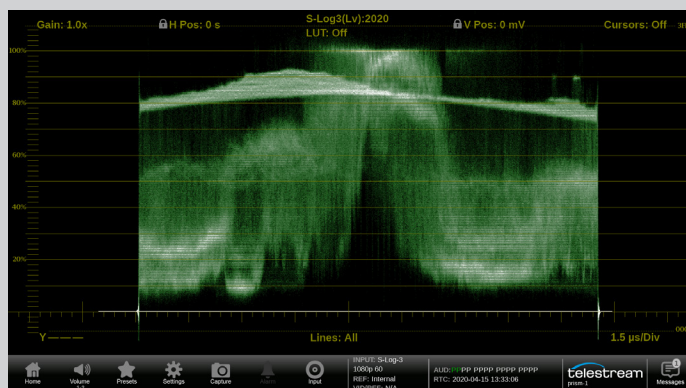

Traditional display in millivolts.

Supported by

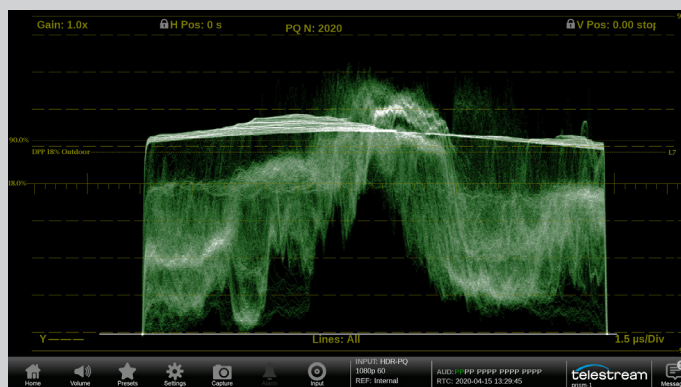

New stop display showing nits on a log scale.

Broadcast operations can identify false colored pictures in their HDR workflows with a new highly configurable false color display with up to 10 false color regions. An optional false color meter shows the currently selected false color regions and their selected limits.

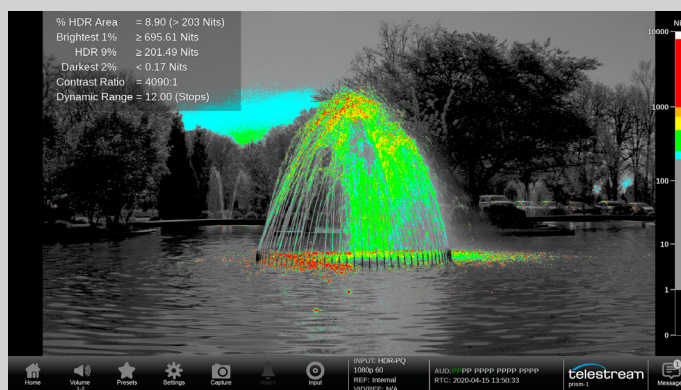

False color display to confirm with standards of brightness, percent HDR and dynamic range of the scene.

The traditional tool for color matching between scenes, setting skin tones, and brand consistency in post-production, is the Vectorscope. When working with wide color gamuts across multiple color spaces, the Vectorscope has limitations, because moving across color spaces has the effect of rotating the color points on the vector trace. To provide a true representation of what is happening in each color space, Telestream has introduced the CIE chart display based on CIE 1931 color space. The PRISM CIE chart display shows regions for Rec 709, DCI-P3 and Rec 2020 enabling operations team to ensure video color gamut are within these standards.

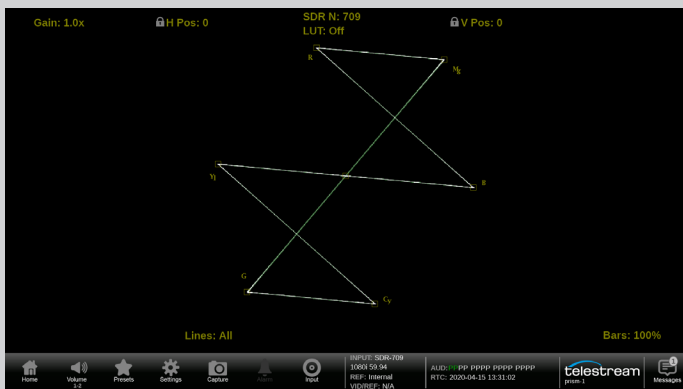

Traditional Vectorscope.

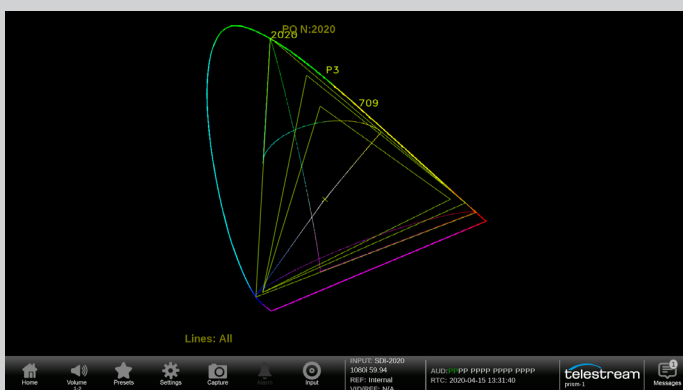

CIE chart display based on CIE 1931 color space.

HDR production is realizing that light level artistic intent should not overdrive the amount of display light, while taking advantage of HDR capabilities to display more detail in darker scenes. A new tool in PRISM provides a readout of the minimum light level (in nits) for the brightest and darkest sets of pixels as a percentage of the screen to confirm creative intent and ensure TV compatibility.



Tektronix PRISM.

Streaming providers like Netflix are increasingly requiring Post facilities to constrain colors to the DCI-P3 colorspace, even when content is encoded in a BT.2020 container to make it easier to remaster in the future when 2020 capable displays are available. A third false color mode from Telestream helps to verify this at the production QC stage, with flexible false color pixel detection outside the BT.709 colorspace or outside the DCI-P3 colorspace when working in a BT.2020 container.

When it comes to HDR and WCG, the workflow of cinema, television and live production are beginning to converge, and objective measurements are required to ensure compliance and to avoid creating content that can't easily be fixed in post-production. Telestream next generation tools can support the existing traditional workflow, and are ready to enable product teams in cinema, television and live production to support the transition and production needs for updated HDR and WCG workflows.

Supported by

For hundreds more high quality original articles and
Essential Guides like this please visit:

thebroadcastbridge.com



04/2020

Supported by

